

**SPECIFICHE GENERALI
GENERAL SPECIFICATIONS**

Materiale contenitore Housing material	Ottone naturale Natural brass
Funzionamento Operation	NC con i due componenti vicini NC when the two components are near
Temp. di funzionamento Operating temperature	-25°C ÷ +50°C
Grado di protezione IP degree	Certificato IPx2 (dichiarato IP65 da Cooper CSA) Certified IPx2 (declared IP65 by Cooper CSA)
V max	24 Vcc - 24 Vca
I max	100 mA
W max	1 W
Identificazione Identification	Numero seriale/lotto su ogni componente Serial number/batch on each component

I contatti magnetici sono componenti passivi, le grandezze elettriche indicate sono le massime applicabili
Magnetic contacts are passive components, max applicable voltage and current are displayed in table

EN50131-2-6

GR 2

CL III

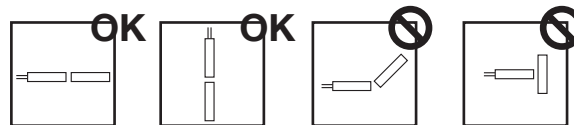
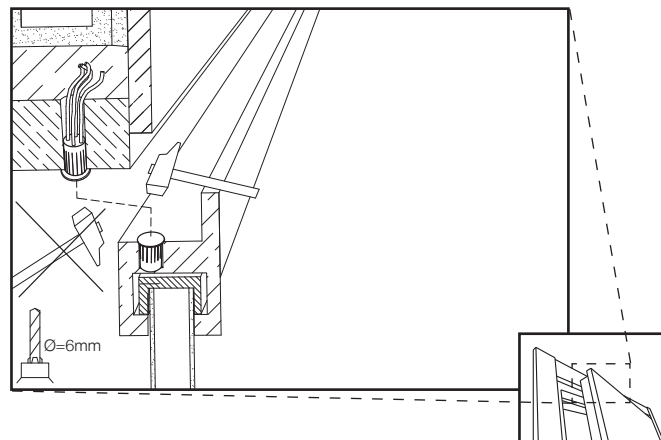
**INSTALLAZIONE CONFORME ALLA NORMA
INSTALLATION AS PER STANDARD**

La certificazione decade per installazioni diverse da quelle rappresentate nelle figure.
Certification is void if the devices are installed differently.

DISTANZE OPERATIVE / OPERATIONAL APPROACH AND REMOVAL DISTANCES

Installare i due corpi a distanza Y inferiore a 10mm (distanza raccomandata 7mm). Le distanze operative riportate in tabella per l'asse Z sono state calcolate con i corpi installati alla distanza raccomandata. Non installare su superfici ferromagnetiche.

Install the two components at Y distance less than 10mm (recommended 7mm). The operating distances displayed in table for the axis Z have been calculated with the components mounted at the recommended distance. Do not install on ferromagnetic surfaces.

Asse / Axis	Z		Y	
Azione / Action				
Contatto / Contact				
Superfici non ferromagnetiche Non-ferromagnetic surfaces	7 mm	10 mm	10 mm	12 mm
Superfici ferromagnetiche Ferromagnetic surfaces				
Tolleranze / Tolerance	-0% +40%	+0% -30%	-0% +20%	+0% -20%

INDICAZIONI DI FISSAGGIO / FIXING INSTRUCTIONS

Fissare le parti tenendo conto delle distanze operative riportate in tabella. Non applicare su superfici ferromagnetiche.

Fix the elements paying attention to the operational approach and removal distance. Do not apply on ferromagnetic surfaces.

COLLEGAMENTO / WIRING

