

iconnect



2-Way Wireless Indoor Siren Installation Guide

For more detailed information please refer to the iConnect 
Installer Manual provided on our website: www.electronics-line.com



UPGRADING
EVERYDAY
SECURITY

Table of Contents

1. Introduction.....	3
2. Location of the Siren.....	3
3. Registering the Siren.....	3
4. Mounting the Siren	4
5. Testing the Siren.....	5
6. Deleting a Siren.....	5
7. Technical Specification.....	6

1. Introduction

The EL-4723 is a 2-Way Wireless Indoor Siren for use with the iConnect 2-Way security system. In the event of an alarm the control system activates the siren. The Wireless Indoor Siren is sounded until the end of the control-system-programmed siren cutoff.

2. Location of the Siren

Consider the following before mounting the Siren:

- Choose a suitable mounting location for the Siren.
- The Siren should be mounted on a flat surface in a highly visible position for maximum deterrence against potential intruders.
- Before permanently mounting the Siren, test the reception from the exact mounting position.

Note:

Always wear ear protectors when installing indoor/outdoor Sirens

3. Registering the Siren

The EL-4723 must identify itself to the iConnect 2-Way receiver as follows:

1. Set the system to registration mode.
 - Go to the main menu and select [9]>[1]>[5]>[1] (Programming > Devices > Siren>WL Siren)
 - Select a siren from the list (1-4) and press '√'.
2. Release the mounting bracket captive locking screw (see Figure 3-1).

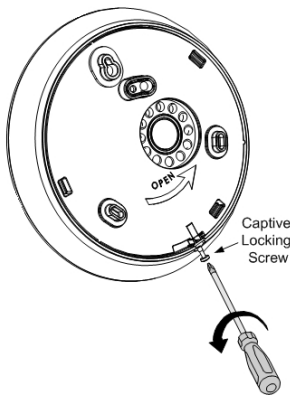

Figure 3-1: Releasing the locking screw

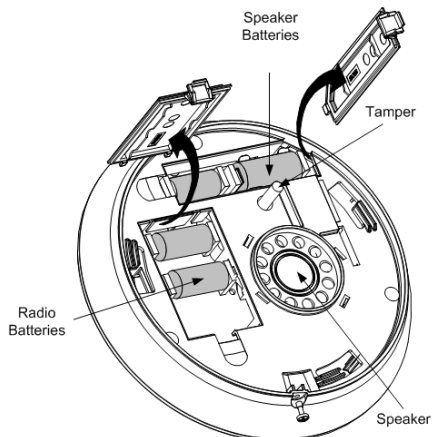

Figure 3-2: Inserting the batteries

3. Open the housing – lift the front cover away from the rear housing.
4. Insert the batteries while paying attention to polarity (see Figure 3-2 and Figure 3-3).

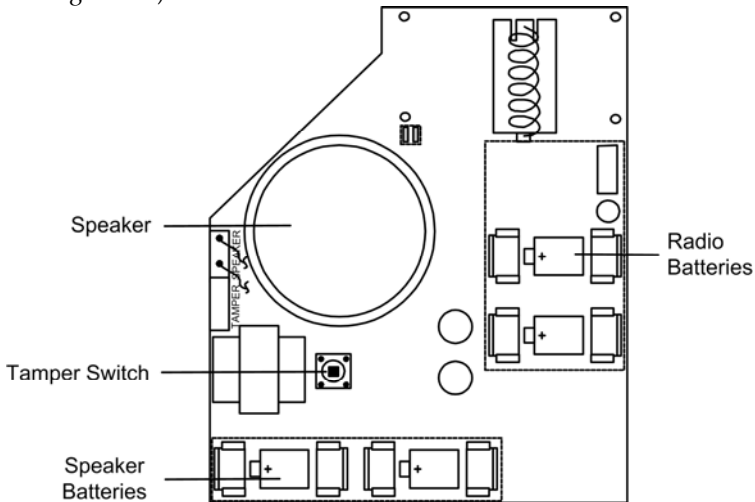

Figure 3-3: Inserting the batteries #2

5. The Siren will send a transmission. If the transmission is successfully received by the system it will play a confirmation sound. If no confirmation sound is heard send another transmission by pressing and releasing the tamper switch of the Siren.
6. As soon as 'Save?' appears press '√'.

4. Mounting the Siren

After the Siren has been registered mount the unit as follows:

1. Place the back cover in position against the wall and mark the upper and lower mounting holes.
2. Install wall anchors in the appropriate positions.
3. Attach the back cover to the wall using supplied screws (see Figure 4-1).

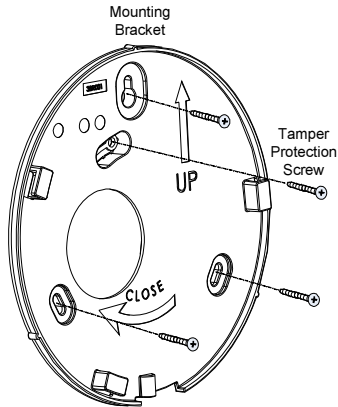

Figure 4-1: Attaching the mounting bracket

4. Mount the Siren to the mounting bracket by turning the Siren clockwise.
5. Secure the captive locking screw (see Figure 3-1)

5. Testing the Siren

Once the Siren has been registered test the unit according to the following testing procedure:

To perform a Siren test

1. Go to the main menu and select [7]>[0]>[3]>[1] (Service> Tests> WL Siren Test).
2. Select a siren from the list (1-4) and press '√'. The selected Siren is sounded briefly.

6. Deleting a Siren

To delete a Siren from the system:

1. Set the system to Delete mode.
2. Go to the main menu and select [9]>[1]>[5]>[1] (Programming > Devices > Siren>WL Siren)
3. Select a siren from the list (1-4) and press '√'.
4. Press >3, and press'√'. Upon the 'OK' confirmation request, press '√'
5. Open the Siren and take out the battery.
6. Press the tamper switch. While the tamper switch is being pressed insert the battery. Within five seconds open the tamper and close it again.

7. Technical Specification

Frequency:	868MHz or 433MHz
Power:	4 X CR123, 3V Lithium Battery (2 batteries for the Radio Transceiver, 2 batteries for the Speaker)
Current Consumption (Radio):	25mA (transmission) 40µA (standby)
Current Consumption (Speaker):	50µA (standby) Maximum: 1.5A
Battery Life:	3 years (typical)
Siren Output:	105dB @ 1m
Tamper Protection:	Front cover, removal from wall
Temperature:	-25°C to 60°C (-4°F to 140° F)
Dimensions:	Ø183 x 51 mm (7.2 x 2 inch)

*Complies with EN 50131-4 Grade 2 Class II

Electronics Line Limited Warranty

EL and its subsidiaries and affiliates ("Seller") warrants its products to be free from defects in materials and workmanship under normal use for 24 months from the date of production. Because Seller does not install or connect the product and because the product may be used in conjunction with products not manufactured by the Seller, Seller cannot guarantee the performance of the security system which uses this product. Sellers' obligation and liability under this warranty is expressly limited to repairing and replacing, at Sellers option, within a reasonable time after the date of delivery, any product not meeting the specifications. Seller makes no other warranty, expressed or implied, and makes no warranty of merchantability or of fitness for any particular purpose. In no case shall seller be liable for any consequential or incidental damages for breach of this or any other warranty, expressed or implied, or upon any other basis of liability whatsoever. Sellers obligation under this warranty shall not include any transportation charges or costs of installation or any liability for direct, indirect, or not be compromised or circumvented; that the product will prevent any persona; injury or property loss by intruder, robbery, fire or otherwise; or that the product will in all cases provide adequate warning or protection. Buyer understands that a properly installed and maintained alarm may only reduce the risk of intruder, robbery or fire without warning, but is not insurance or a guaranty that such will not occur or that there will be no personal injury or property loss as a result. Consequently seller shall have no liability for any personal injury, property damage or loss based on a claim that the product fails to give warning. However, if seller is held liable, whether directly or indirectly, for any loss or damage arising from under this limited warranty or otherwise, regardless of cause or origin, sellers maximum liability shall not exceed the purchase price of the product, which shall be complete and exclusive remedy against seller. No employee or representative of Seller is authorized to change this warranty in any way or grant any other warranty.

WARNING: This product should be tested at least once a week.

CAUTION: Risk of explosion if battery is replaced by an incorrect type. Dispose of used batteries according to local regulations.

Contacting Electronics Line 3000 Ltd.



International Headquarters:

Electronics Line 3000 Ltd.

14 Hachoma St., 75655

Rishon Le Zion, Israel

Tel: (+972-3) 963-7777

Fax: (+972-3) 961-6584

All rights reserved.

No part of this document may be reproduced in any form without prior written permission from the publisher